

VOLTAGE MONITOR

Zero-Tolerance Solution
to prevent electric shocks

JSC-88A



DESCRIPTION

The **JSC-88A** is a very reliable detection unit designed to indicate visually whether or not the voltage on a given system is at «Energy 0». It drastically improves the security for maintenance teams working on three-phase systems. As long as voltage is present downstream of the breakers, the JSC-88A LEDs will remain lit, allowing for a rapid visual inspection for the presence or absence of hazardous voltages. The use of the optional KLQ-Kit gives an additional security by providing a visual indication at the motor site.

The JSC-88A, thanks to its small size and light socket mounting design, is easy and quick to install on the door of any starter panel. Originally developed for Alcan (the well-known International Aluminium Smelting company), this voltage monitor has been in large scale use since 1988 in a number of international industrial environments.

When it is time for maintenance and you open the disconnect-switch or breakers, **ARE YOU 100% SURE THAT NO VOLTAGE IS PRESENT ?**

One of the hazards of today's plants is working on three-phase systems. Why is this a hazard ? Because it is difficult to be absolutely certain that the power is truly « OFF » once the disconnect switch or breaker has been opened.

HUMAN ERRORS & HAZARDOUS ENVIRONMENTS

Accidents happen ... mostly due to human error:

- Incorrect measurement setup
- Incorrect readings
- Lapse of concentration

Accidents also happen due to hazards in the environment:

- Carbon deposits (providing electrical path for the current)
- Defective voltmeter or accessories
- Sticking switch blades
- Dual sourcing
- Defective electronic breakers which are difficult to diagnose
- Any other hazardous situation that allows for conduction after the breaker or disconnect-switch has been opened

The JSC-88A helps prevent accidents

We can now help prevent electrocutions in the work place, thanks to the **JSC-88A Voltage Monitor**.

How to use the JSC-88A ... in two easy steps

To use the JSC-88A properly, the following steps must be followed carefully:

STEP #1- While the breakers are still in the « ON » position, make sure that the three(3) LEDs on the JSC-88A are « ON » (or lit), indicating that the JSC-88A is working properly and that voltage is present downstream of the breakers.

Important note : If any of the LEDs is not lit at this stage, an authorized staff member should investigate the problem and take appropriate corrective action before proceeding with STEP#1 again.

STEP #2- As soon as the breakers have been switched to the « OFF » (or Zero-Energy) position, examine the JSC-88A again and make sure the three(3) LEDs are now « OFF », (i.e. not lit) indicating that voltage is no longer present downstream of the breakers.

Important note : One or more of the LEDs will remain « ON » if the JSC-88A detects any voltage (or any current leakage greater than 2mA). This would indicate a serious electrical hazard. An authorized staff member should investigate the problem and take appropriate corrective action before maintenance work proceeds.

CONTACT YOUR LOCAL DISTRIBUTOR

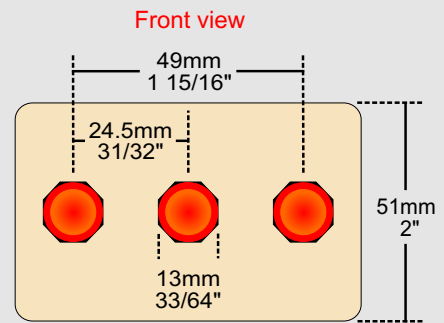
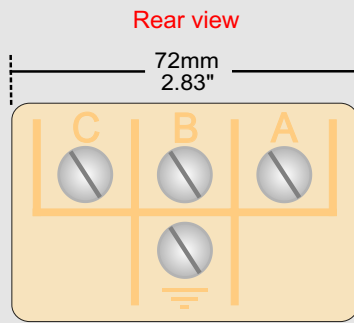
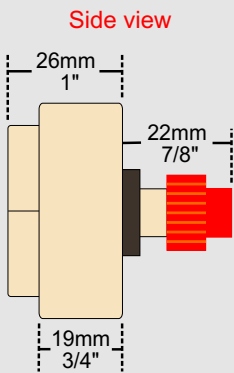

FEATURES

High-Quality Solution

A full 2-year warranty

UL and CSA certified

Encased in epoxy, hence 100% resistant to hostile, humid and dusty environments

High Sensitivity

Can detect and indicate any current leakage greater than 2mA

Easy-to-install

Meets NEMA-4X certification (standard).

For more informations, see « Specifications »

High Luminescent Visual Indicator

Since the indicators are luminescent (special low-current LEDs), readings are not affected by ambient light. They can be seen regardless of their placement on the MCC (motor control center).

SPECIFICATIONS

Normal Operating voltage

The JSC-88A comes with a universal voltage reduction kit that permits operation from 208 volts to 600 volts.

Max. current consumption

1.9 mA

Dimension

72mm X 51mm X 26mm

NEMA-4X

(For more information: <http://www.ul.com/hazloc/ref/Nema.htm>)

Indoor or outdoor use primarily to provide a degree of protection against corrosion, windblown dust and rain, splashing water, hose-directed water, and damage from external ice formation.

IMPORTANT NOTE: Concerning installation of the JSC-88A

For proper and safe operation, the JSC-88A requires a link to neutral (or ground where permitted). **The JSC-88A is not recommended on a true floating systems.** In that case, use the JSC-88K6 (limitations apply). For more informations on JSC-88A or JSC-88K6, visit the following website: <http://www.controlab-pulsar.com/JSC88.htm>

ORDERING INFORMATION

NEMA-4X Series for "Y" or "Delta" systems with ground

JSC88A Standard unit for 208 volts c/w KA reducer kit

KA Voltage reducer kit for 208 volts to 600 volts

KLQ-Kit Optional remote light kit

Name plate used as a drill guide

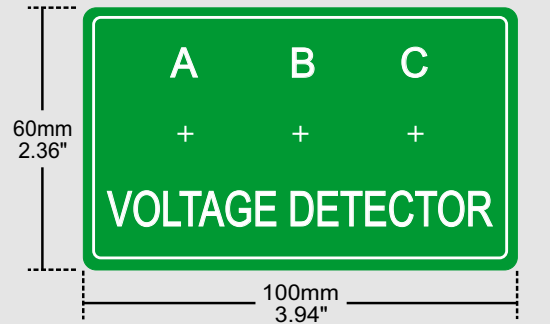

INSTALLATION

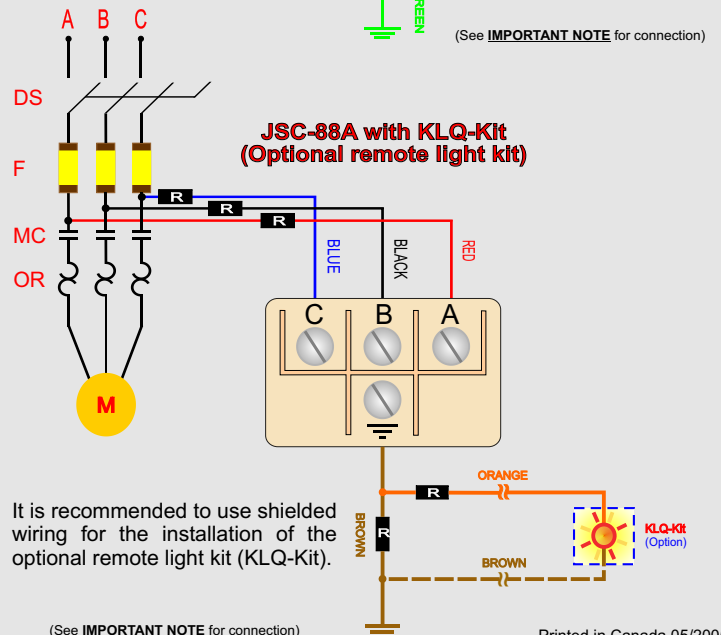
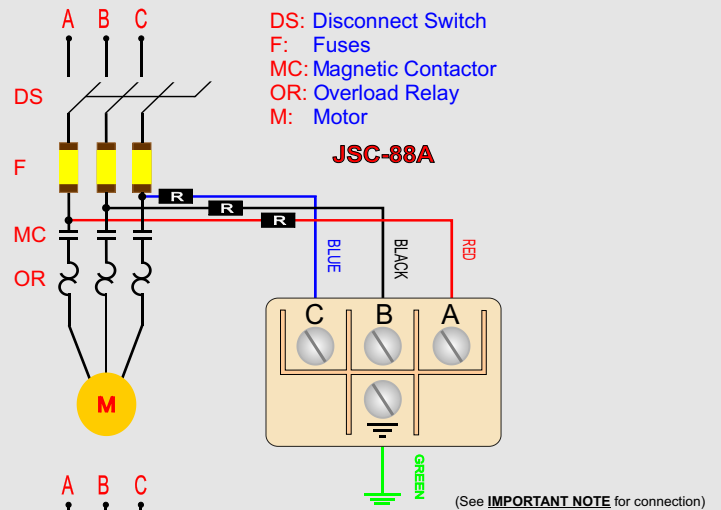

It is recommended to use shielded wiring for the installation of the optional remote light kit (KLQ-Kit).

(See IMPORTANT NOTE for connection)

Printed in Canada 05/2005